

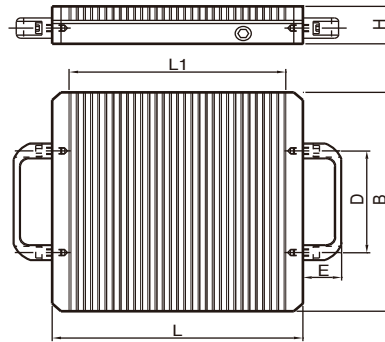

● Micro pitch permanent magnetic pallet chuck

Use:
Clamping for palletizing system

- Features:**
- Pole pitch 0.5+1.5 mm
 - Max magnetic clamping force up to 120 N/cm²
 - No residual magnetism
 - High precision and low flux depth 6 mm
 - Very light switching force
 - High accuracy guaranteed through entire service life



Model	Width (B)	Length(L)	Height(H)	L1	D	E	Net Weight
PPC-2424/40	240 (9.45)	240 (9.45)	40 (1.57)	197 (7.76)	130 (5.12)	40 (1.57)	16 kg / 35 lb
PPC-2828/40	280 (11.02)	280 (11.02)	40 (1.57)	237 (9.33)	130 (5.12)	40 (1.57)	22 kg / 48 lb
PPC-3232/40	320 (12.60)	320 (12.60)	40 (1.57)	279 (10.98)	130 (5.12)	40 (1.57)	28 kg / 62 lb

Unit: mm(in)



● Permanent magnetic pallet chuck for milling

Use:
Clamping for palletizing system

- Features:**
- Pole pitch 4+11 mm
 - Max. Magnetic clamping force up to 180 N/cm²
 - No residual magnetism
 - Strong clamping force with low flux depth 12 mm
 - Easy to activate and de-activate
 - High accuracy guaranteed through entire service life

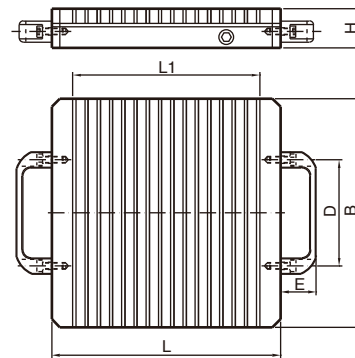

Model	Width(B)	Length(L)	Height(H)	L1	D	E	Net Weight
PPM-2424-48	240 (9.45)	240 (9.45)	48 (1.89)	184 (7.24)	130 (5.12)	40 (1.57)	19 kg / 42 lb
PPM-2828-48	280 (11.02)	280 (11.02)	48 (1.89)	214 (8.43)	130 (5.12)	40 (1.57)	20 kg / 57 lb
PPM-3232-48	320 (12.60)	320 (12.60)	48 (1.89)	259 (10.20)	130 (5.12)	40 (1.57)	35 kg / 77 lb

Unit: mm(in)